Neodent[®] Guided Surgery MANUAL

GRAND MORSE[®]



*GRAND
POSSIBILITIES
WITH A LIMITLESS
SOLUTION.*

*GRAND MORSE® NEODENT®
GUIDED SURGERY.*

CONTENTS

1. CLINICAL STEP BY STEP OF

GRAND MORSE® NEODENT® GUIDED SURGERY (GM NGS)	4
1.1. Diagnostic / Data Acquisition	4
1.2. Virtual Planning	4
1.3. Surgical Guide Production	4
1.4. Surgical procedures with GM NGS System	4
2. GM NGS - CONCEPT	5
2.1. General Aspects	5
2.2. Surgical Guide - Types of Support	5
2.3. GM NGS Fixation Clamps	6
2.4. GM NGS Sleeves	7
2.5. GM NGS Drill Guide	9
3. GM NGS SURGICAL KIT	10
3.1. GM NGS Punch (optional)	11
3.2. GM NGS Drills	11
3.3. GM NGS Connections	13
3.4. GM NGS Stabilizer (optional)	15
4. CLINICAL WORKFLOW	16
4.1. Narrow Sleeve Diameter	16
4.2. Regular Sleeve Diameter	17
4.3. Wide Sleeve Diameter	18

1. CLINICAL STEP BY STEP OF GRAND MORSE® NEODENT® GUIDED SURGERY (GM NGS)

Neodent® Guided Surgery (NGS) Instruments are intended for procedures with 3D planning software through Cone Beam Computer Tomography (CB(CT)) images. They are designed to prepare the osteotomy and perform the implant placement of Neodent® GM implants in combination of surgical guide including the Neodent® Sleeves.

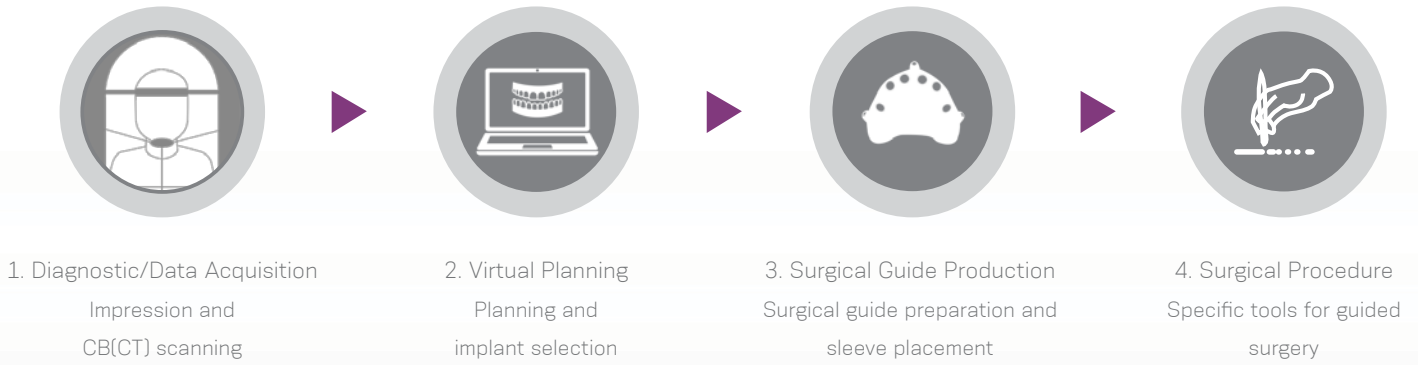

1.1. Diagnostic / Data Acquisition

Chair side diagnostics and patient-specific requests influences on treatment plan. It is needed to take in account: bone volume, bone density; anatomy of the area to be restored; type of restoration; type of loading, number of implants; esthetic and functional factors; and any other important considerations supporting the treatment plan for guided surgery.

Regardless of imaging technology, a CB(CT) scan (respecting right parameters) is the basis for a precise digital plan and for accurate implant placement. In order to get the optimal scan data, the radiologist and the patient has to be correctly instructed and scanning instructions/parameters must be followed according to the software manufacturer instruction for use (IFU). A dental impression is required and could be done conventionally or digitally.

*Note: For guided surgical procedures, the patient's mouth opening capability needs to be sufficient to accommodate the instruments of guided surgery.

1.2. Virtual Planning

The 3D dataset (DICOM) can be imported directly into commercially available planning softwares (e.g. coDiagnostiX) and overposed with the dental impression taken from the scanners (STL file). The implant is positioned with respect to the patient's anatomy and desired prosthetic outcome.

1.3. Surgical Guide Production

Once the virtual planning is completed successfully, the treatment plan is sent to the surgical guide manufacturer. The software manufacturer or the dental laboratory may fabricate the surgical guide depending on the software concept used.

*Note: In this step, the surgical guide manufacturer ensures the compatibility with the NGS Instruments by using Neodent® sleeves for guided surgery, positioned according to Neodent® parameters.

1.4. Surgical procedures with NGS System

After having fixed the surgical guide in the patient's mouth, optionally with the Neodent® Fixation Clamp, the osteotomy for the Neodent® GM implant line can be prepared with the Neodent® Guided Surgery Instruments included in the Neodent® Guided Surgery Kit. The surgical protocol, provided together with the surgical guide, recommends which instruments are required to prepare each implant site. NGS instruments allow guided insertion of implants, through the surgical template including depth control (marks on the drills - guided surgery GM connection - contra-angle).

2. GM NGS CONCEPT

2.1. General aspects

The patient's mouth opening ability in the region of the implant should be sufficient for proper use of GM NGS drills and connections. The drills and connections used in guided surgery techniques need to compensate for the soft tissue thickness, the sleeve height and, therefore, have considerably greater lengths than the instruments used in conventional techniques. A limited mouth opening may turn difficult to install implants in guided surgery procedures.

The sleeve size is standardized in 4 mm. Therefore, GM NGS system presents 9 or 11 mm (H11- long) between the upper part of the sleeve and the implant platform, which provide enough options of height for soft tissue thickness and subcrestal implant placement.

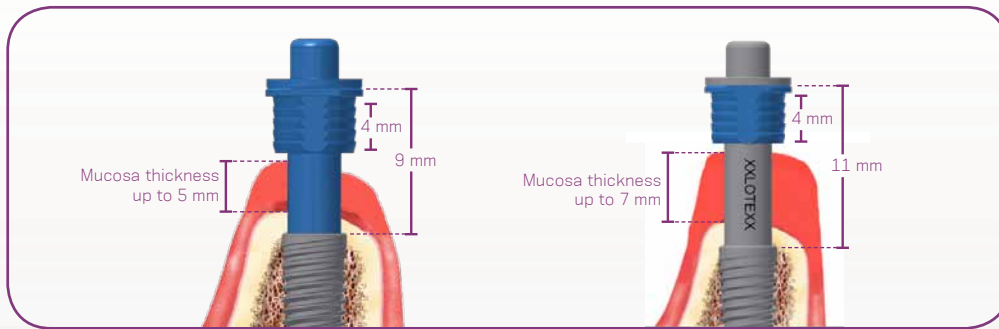

In case of osteotomy to regularize bone ridge or multiple extractions the immediate installation of implants are contraindicated with guided surgery technique due to bone remodeling after these procedure. The physiological ridge reduction process can lead to loss of structure that would be used previous implant installation planning.

2.2. Surgical guide - Types of support

Several types of supports for surgical guides are commercially available (see figures) according to customized surgical indication, considering software planning and guide manufacturer features. All are possible, depending on the dentist's preferences, the planning software used and surgical guide manufacturer.



Mucosa supported surgical guide



Teeth supported surgical guide

2.3. GM NGS Fixation Clamps

GM NGS Fixation Clamps have been designed to ensure stability and fixation of the surgical guide. They are used to maintain the surgical guide at its position from throughout the surgery.



- Drilling speed: 500-800 rpm.
- No drill handle is required for the drilling procedure of the Fixation Clamp.
- Use the intermittent drilling technique until the physical stop of the drill 1.3 mm.
- After the osteotomy, fully engage the Fixation Clamp until the physical stop.

*Note: Procedure not necessary for all cases, specially indicated for fully edentulous patients.

103.395
Guided Surgery
Drill 1.3 mm



125.100
Guided Surgery
Fixation Clamp

Sleeve of Setter for
Guided Surgery (yellow)
125.138
Indicated for the placement
of the Fixation Clamp.



In order to ensure stability, the Fixation Clamp should be placed in an area with a sufficient and adequate bone quality. The Neodent® Sleeve of Setter for Guided Surgery (Fixation clamp) should be surrounded with enough surgical guide material for optimal retention. Additionally, the number of Fixation Clamps has to be adapted to the patient anatomy, type of surgical guide, number and position of implants (examples of recommended position, see figures).



2.4. GM NGS Sleeves

The GM NGS Sleeve is selected according to the mesio-distal space and implant diameter. During the digital planning, sleeve positions have to be evaluated in order to avoid collision. GM NGS offers a comprehensive range of sleeve diameters for optimizing sleeve placement.

- (1) NARROW;
- (2) REGULAR;
- (3) WIDE.

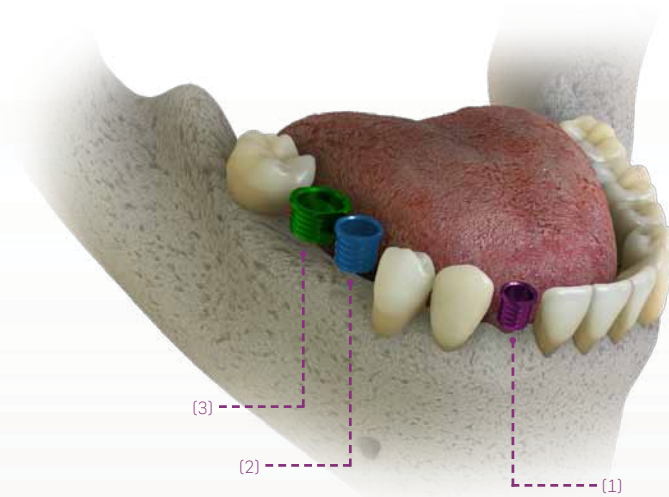

Sleeves measurements according to implant diameters indications.



Model	Indication	(A) Diameter of the Stop (mm)	(B) Internal Diameter (mm)	(C) Body Diameter (mm)	(D) Height (mm)
 Narrow (purple)	Helix GM®: Ø 3.5 Drive GM®: Ø 3.5	4.6	3.5	4	4
 Regular (blue)	Helix GM®: Ø 3.5/3.75/4.0/4.3 Drive GM®: Ø 3.5 / 4.3	6	4.5	5.1	4
 Wide (green)	Helix GM®: Ø 5.0/6.0 Drive GM®: Ø 5.0	7.4	6.2	6.9	4

In narrow dental spaces, the Narrow Sleeve 3.5 mm can be used to prevent sleeve collision.

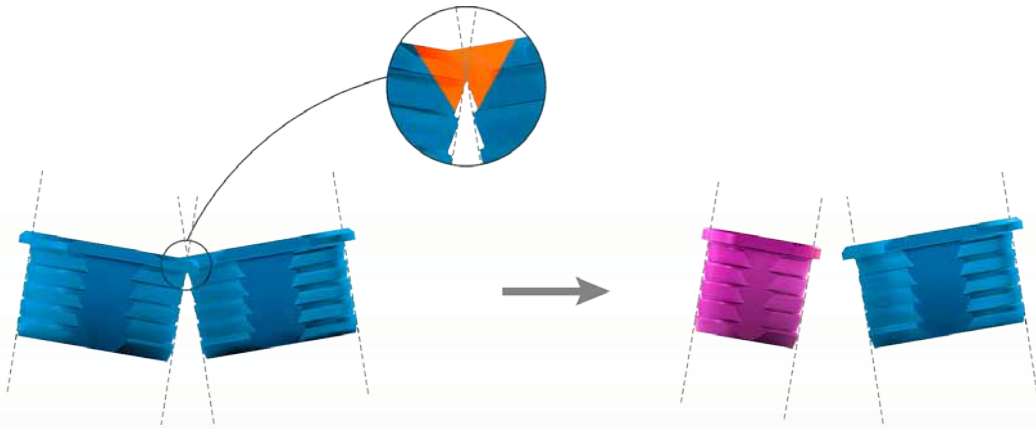

The GM NGS System allows flexible height sleeve position in the surgical guide. The two sleeve positions are 5 mm (H9) or 7 mm (H11), considering 9 and 11 mm from the upper part of the sleeve to the implant platform. For implant length of 18 mm a partial NGS technique is indicated.

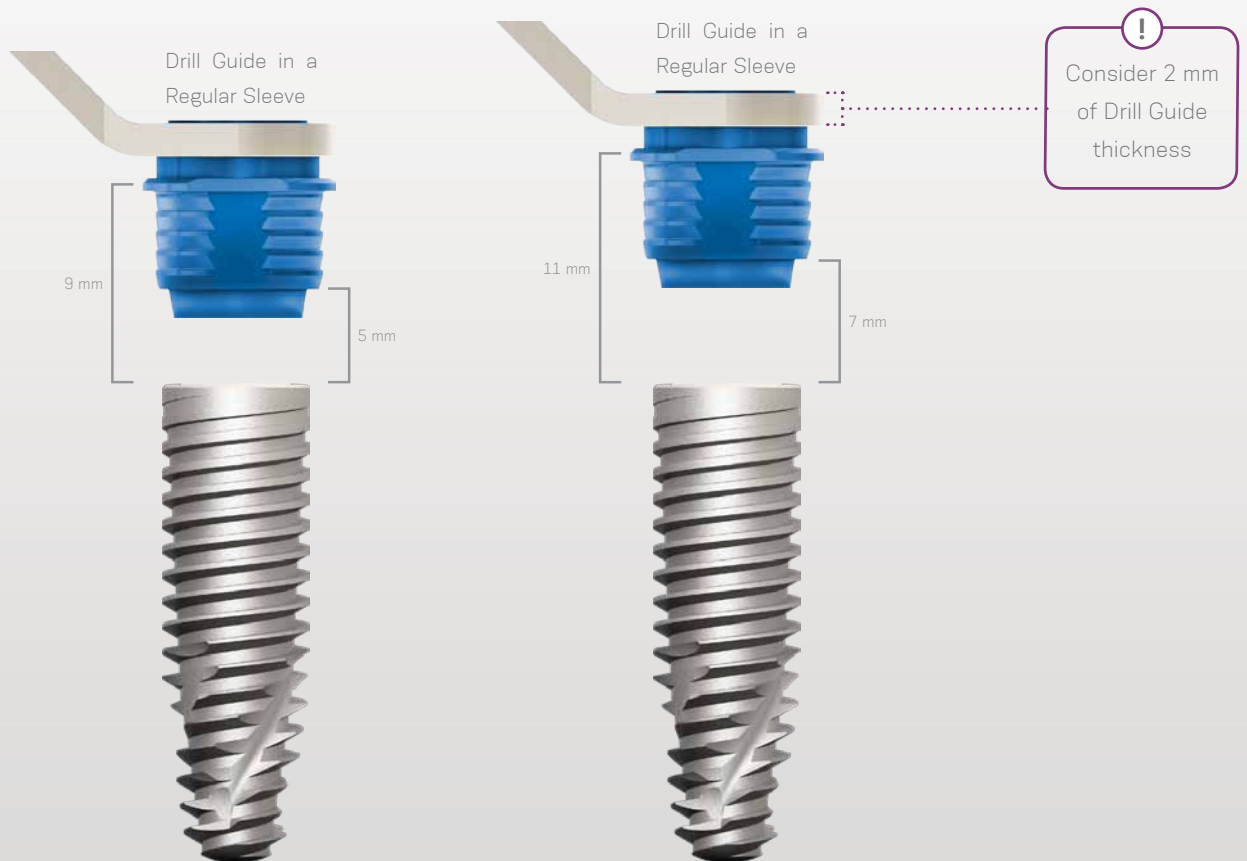

2.5. GM NGS Drill Guide

With an ergonomic design, the GM NGS Drill Guides are based on the reduction sleeve concept (see image below). The cylinder of the drill guide is inserted into the sleeve fixed in the surgical guide.

GM NGS Drill Guides are color-coded according to the sleeve in which they should be placed and are laser marked with the corresponding drill diameter. The drill guide must be placed into the guide sleeves during the drills instrumentation.

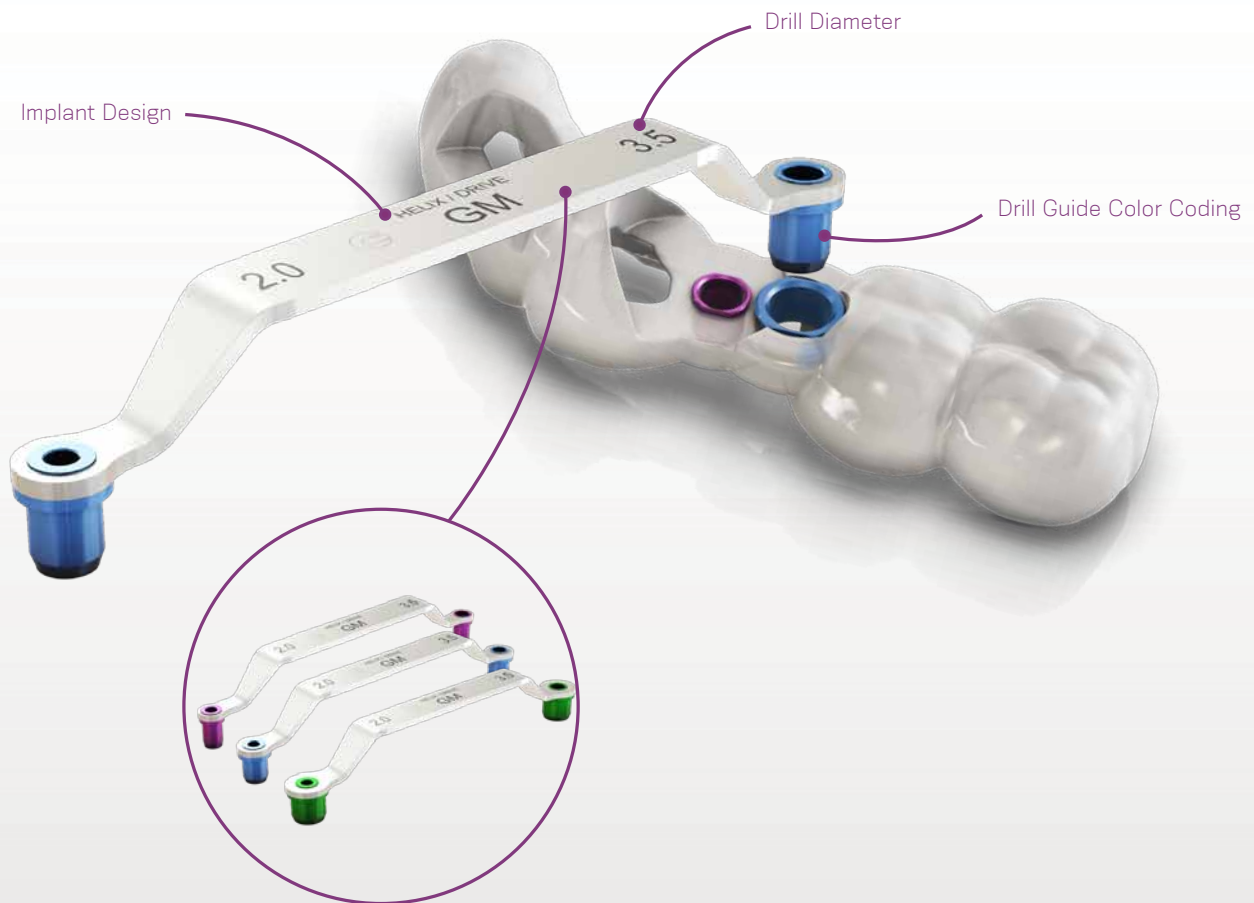

3. GM NGS SURGICAL KIT

The GM NGS Surgical Kit (see figure) has been manufactured using autoclavable polymer. It is used for secure storage and sterilization of surgical and auxiliary instruments. For instructions on cleaning and sterilization procedures, please refer to the correspondent IFU at ifu.neodent.com.br, using the article number in the search field.

- One kit for all bone types.
- Color-coded sequences help for a reliable working process.
- Clear illustrations supports for checking the proper set up of instruments.
- Secured holding of the instruments in the silicone grommets for sterilization and storage.



Complete
Helix® and Drive® Grand Morse®
Implants portfolio



Convenient
Color-coded instruments and
symbol-marked



Flexible
2 sleeve height positions

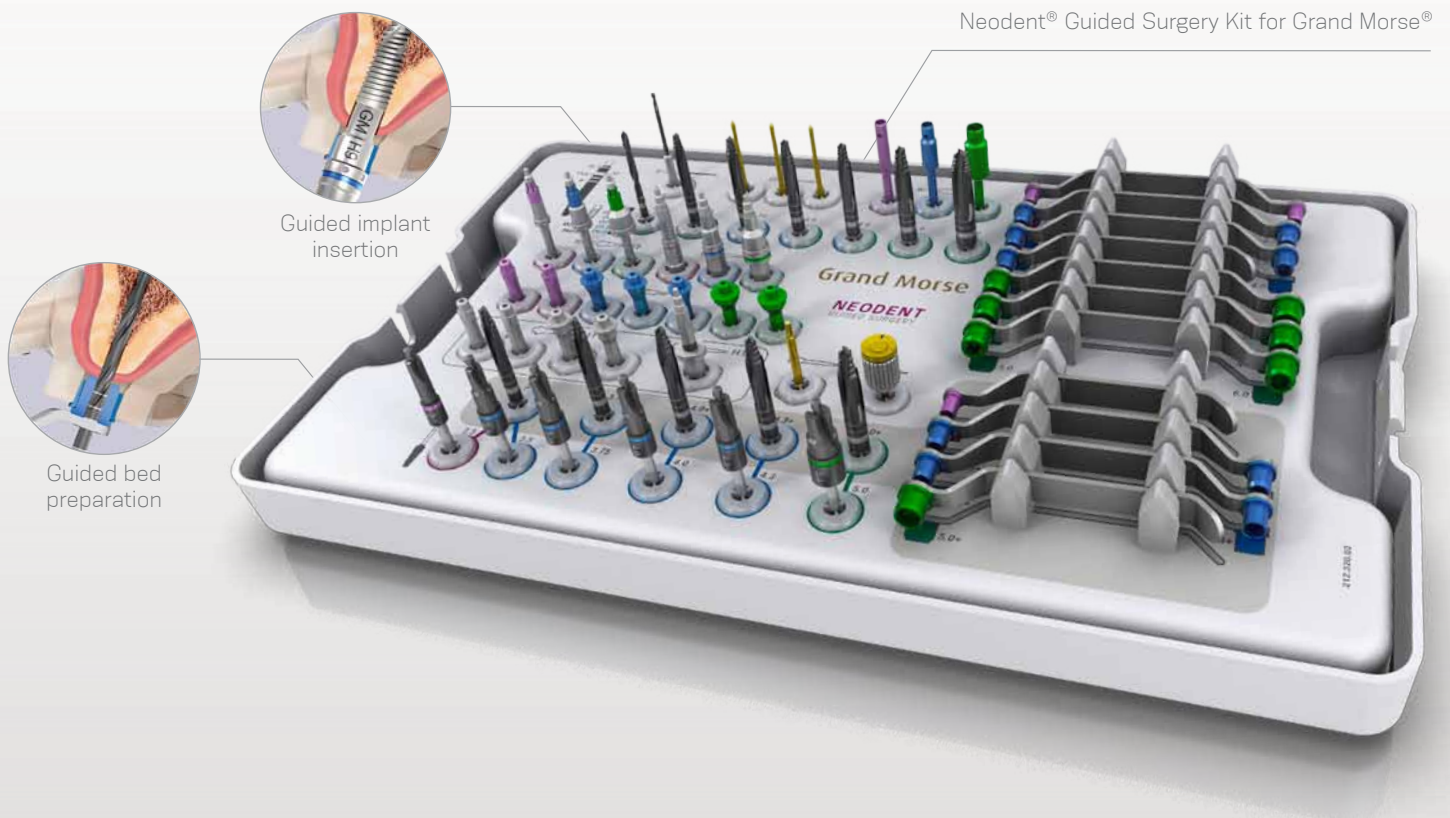

Compatible with major guided surgery software
For more information on software compatibility please go on
www.neodent.com.br/ngs

3.1. GM NGS Punch (optional)

The punch (mucosa extractor) is an optional surgical instrument with a contra-angle fitting on one edge and a cutting cylindrical format on the other. Its indication is for circular incision in the mucosa before bone bed preparation through the guided surgery technique. The punches are color-coded according to the diameter of the sleeve they should be used with: narrow (purple), regular (blue) or wide (green).



Narrow

103.429



Regular

103.430



Wide

103.431

The indicated number of rotations per minute (rpm) for drilling is 60 rpm.

3.2. GM NGS Drills

GM NGS Drills have been exclusively designed for a guided surgery procedure in combination with a surgical guide including the GM NGS Sleeves. The drills have to be used together with the corresponding drill guides and sleeves fixed in the surgical guide.

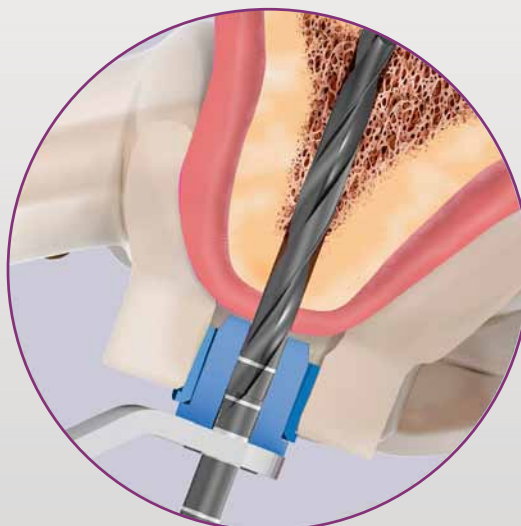

The drills are of the same format as the ones needed to install a Helix® or Drive GM® implant in the conventional workflow, however the length is increased for the guided system. The use of the depth probe is recommended for controlling instrumentation depth. The drills are divided into three types according to its function:

1- Tapered Guided Surgery Drills are indicated to prepare the osteotomy, following the sequence based on implant type and diameter, as chosen in the preoperative plan.

2- Tapered Guided Surgery Contour Drills are especially indicated as supplementary instruments for osteotomy when placing Helix GM® implants in bone types I and II. There are different tapered contour drills to be selected according to implant diameter. These drills are used only on bone types I and II, connected to the contra-angle. This step is intended to keep the insertion torque at a desirable level in bone types I and II. The symbol + is seen in the drill number and also on the drill guide for this drill.

3- Pilot Guided Surgery Contour Drills are employed to prepare the bone around the coronal area of the implant. For bone types I and II preparation, pilot drills help position the platform of GM implants according to the bone bed. Pilot drills are optional in bone types III and IV.



1- Tapered Drill 2- Tapered Contour Drill 3- Pilot Drill

Drilling height	8	10	11.5	13	16
Real height (mm)	19	21	22.5	24	27

- GM NGS Drills :
- The maximum rotation speed used for all drills is 800 rpm for bone types III and IV and 1200 rpm for bone types I and II.
 - Depth lines to ensure depth visualization control and drilling flexibility (H9 or H11).
 - Designed to improve the irrigation, reducing bone heating.
 - Pilot Drills: Start drilling after having inserted completely the drill into the sleeve and does not go with drill guide.

* Note: 18 mm-long GM implants are indicated for partial NGS technique.

GM NGS also offers the possibility of using short versions of tapered and tapered contour drills. They are 4.5 mm shorter than the regular drills and especially indicated for procedures in the posterior region or for patients with mouth opening limitations.



Regular Guided Surgery Drill

Short Guided Surgery Drill

*Note: The fully guided technique with the short drill version is indicated for 8, 10 and 11.5 mm-long GM implants.

3.3. GM NGS Connections

Neodent® GM implants were developed to begin placement with contra-angle or manually, and finished with the torque wrench. The maximum recommended rotation speed for implant installation is 30 rpm, with a torque of 32 N.cm.

GM NGS Connections fit the sleeve in the surgical guide and ensure for fully-guided implant insertion, providing physical depth control. It allows subcrestal implant placement, due to the consistency of diameters between connection and implant. The dimples indicates the position of the Internal Exact, turning the prosthetic workflow more practical, as it shows the orientation in which the abutment should be installed.



GM NGS Connections allows for fully-guided insertion of GM Implants through color-coded GM NGS Sleeves and ensures the right positioning with physical depth control. There are two models of GM NGS Connections:

- For Contra-angle: to capture the implant from the packaging and start the installation

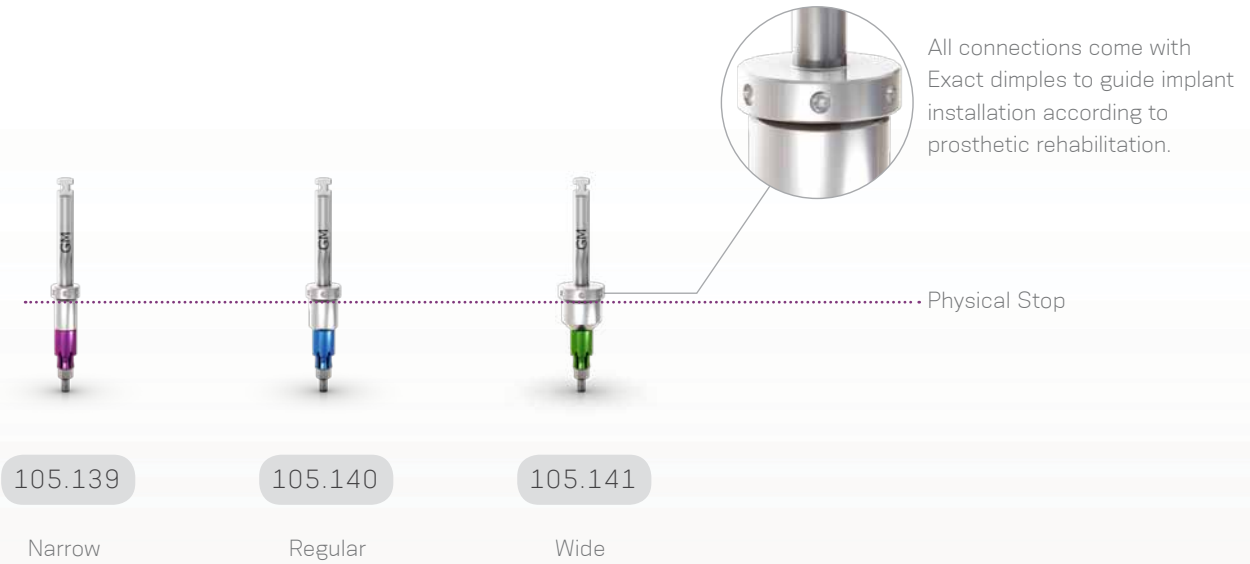

- * For Torque Wrench: to finalize the installation and to measure the insertion torque.



- Fits the surgical sleeve and ensures for fully-guided implant insertion providing physical depth control.
- Consistent diameter between the implant driver and the implant diameter allows subcrestal implant placement.
- Internal Exact position indicator allows for visualization of the implant connection position.

3.4. GM NGS Stabilizer (optional)

Additional stabilization of the surgical guide can be achieved by anchoring it with Guide Stabilizers. Protect the Surgical Guide Stabilizer against aspiration. They are especially indicated when multiple tooth loss jeopardize the stability of the surgical guide. For H9 sleeve height, there is one model of Guide Stabilizer for each sleeve diameter, following the same color code. For H11 sleeve height, there are narrow and regular Guide Stabilizer options.

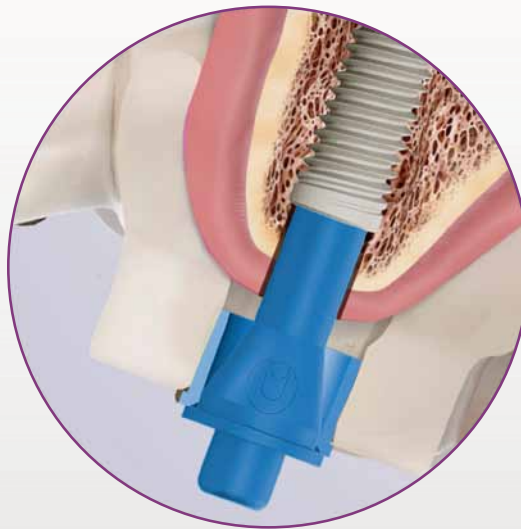









! At H11 there are 2 Stabilizers diameters for Narrow and Regular Sleeves, which are not color-coded.

Insert the Guide Stabilizer after implant placement using the Neo Manual Screwdriver, fully engaging it until the physical stop. Hand torque it gently. Do not use the Guide Stabilizer when implant primary stability is lower than 20 N.cm.

4. CLINICAL WORKFLOW

Drill and connections sequence according to guide drill positioning

4.1. Narrow Sleeve Diameter

	Tapered Drills			Tapered Contour and Pilot Drills		Connections	
	Narrow Punch	Ø 2.0	Ø 3.5	Ø 3.5+	Ø 3.5		
							
	103.429	103.432*	103.433*	103.439*	103.444	105.139	105.142
 Helix GM® Ø 3.5	Optional	✓		✓	✓	✓	✓
 Helix GM® Ø 3.5	Optional	✓	Optional			✓	✓
Drive GM® Ø 3.5	Optional	✓	✓		Optional	✓	✓

*Note: the regular tapered and tapered contour drills can be replaced with their short versions. In that case, 13, 16 and 18 mm-long GM implants are indicated for partial NGS technique, as the short drills only have marks corresponding to 8, 10 and 11.5 mm osteotomies.

4.2. Regular Sleeve Diameter

		Tapered Drills					Tapered Contour and Pilot Drills								Connections		
		Regular Punch	Ø 2.0	Ø 3.5	Ø 3.75	Ø 4.0	Ø 4.3	Ø 3.5+	Ø 3.75+	Ø 4.0+	Ø 4.3+	Ø 3.5	Ø 3.75	Ø 4.0	Ø 4.3		
		103.430	103.432	103.433	103.434*	103.435	103.436*	103.439*	103.440*	103.441*	103.442*	103.445	103.446	103.447	103.448	105.140	105.143
Helix GM®	Ø 3.5	Optional	✓					✓				✓				✓	✓
	Ø 3.75	Optional	✓	✓					✓				✓			✓	✓
	Ø 4.0	Optional	✓	✓	✓					✓				✓		✓	✓
	Ø 4.3	Optional	✓	✓		✓					✓				✓	✓	✓
Drive GM®	Ø 3.5	Optional	✓	Optional												✓	✓
	Ø 3.75	Optional	✓	✓	Optional											✓	✓
	Ø 4.0	Optional	✓	✓	✓	Optional										✓	✓
	Ø 4.3	Optional	✓	✓	✓		Optional									✓	✓
Drive GM®	Ø 3.5	Optional	✓	✓								Optional				✓	✓
	Ø 4.3	Optional	✓	✓			✓								Optional	✓	✓

*Note: the regular tapered and tapered contour drills can be replaced with their short versions. In that case, 13, 16 and 18 mm-long GM implants are indicated for partial NGS technique, as the short drills only have marks corresponding to 8, 10 and 11.5 mm osteotomies.

4.3. Wide Sleeve Diameter

	Tapered Drills						Tapered Contour and Pilot Drills		Connections			
	Wide Punch	125.126		125.127		125.128		125.129				
		Ø 2.0	Ø 3.5	Ø 4.0	Ø 4.3	Ø 5.0	Ø 6.0	Ø 5.0+	Ø 5.0			
		103.430	103.432*	103.433	103.435*	103.436*	103.437*	103.438*	103.443*	103.449	105.141	105.144
Helix GM® Ø 5.0	Optional	✓	✓	✓	✓			✓	✓	✓	✓	
Helix GM® Ø 5.0	Optional	✓	✓		✓	✓				✓	✓	
Helix GM® Ø 6.0	Optional	✓	✓		✓	✓	Optional			✓	✓	
Drive GM® Ø 5.0	Optional	✓	✓		✓	✓		Optional		✓	✓	

*Note: the regular tapered and tapered contour drills can be replaced with their short versions. In that case, 13, 16 and 18 mm-long GM implants are indicated for partial NGS technique, as the short drills only have marks corresponding to 8, 10 and 11.5 mm osteotomies.

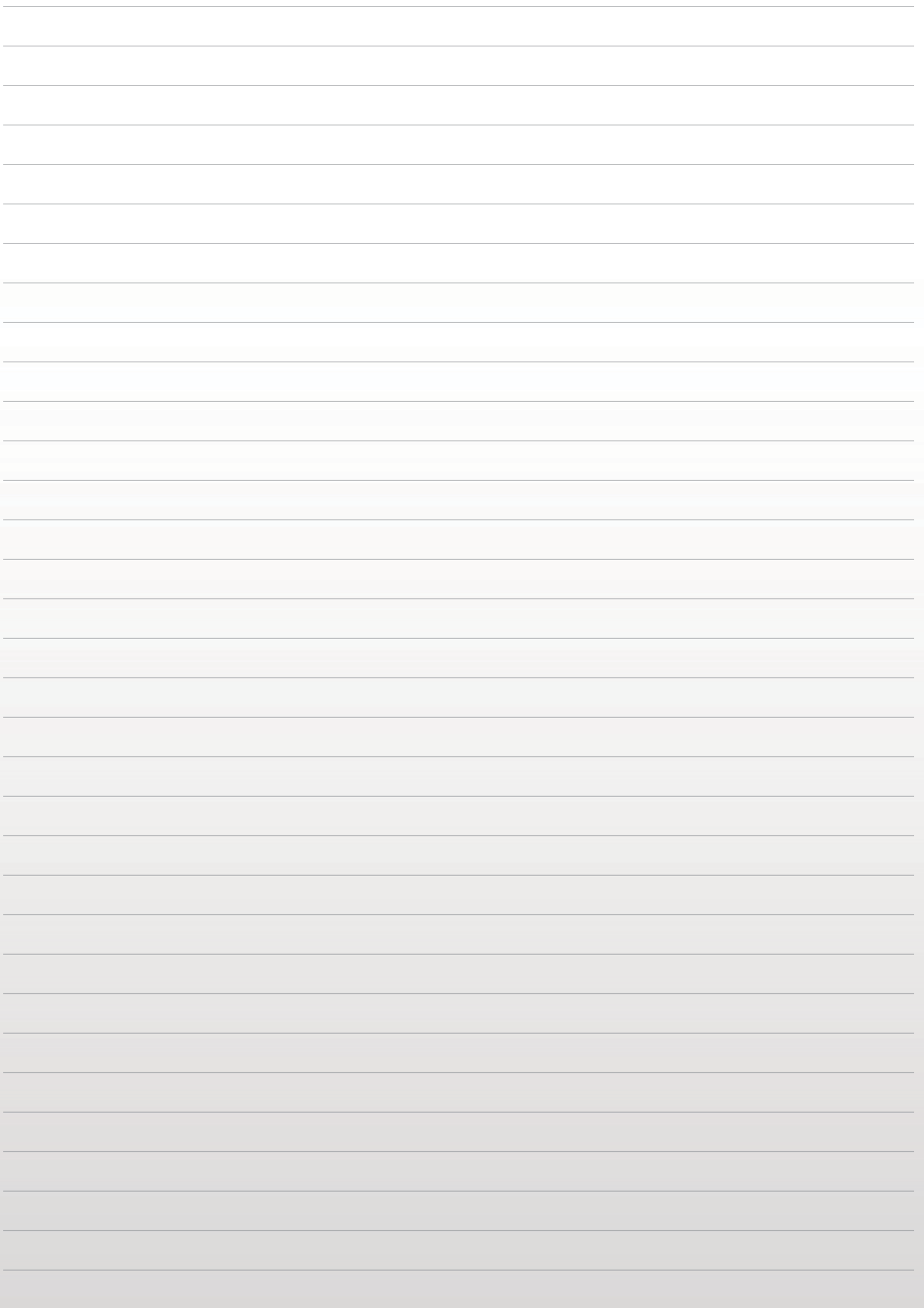

© 2019 - JJGC Indústria e Comércio de Materiais Dentários S.A. All rights reserved.
Neodent®, Grand Morse®, Helix®, Helix GM®, Drive® and Drive GM® are trademarks or
registered trademarks of JJGC Indústria e Comércio de Materiais Dentários S.A.
coDiagnostiX is a trademark or registered trademark of Straumann Holding AG.
Reproduction without prior permission is forbidden.

10650_neodent_gm_manual_en_eU_B01_hr_280519

MRK.053.Rev.01

Distributed in Israel



H&A Systems

11 Tuval St.

Ramat-Gan 5252226, Israel

Phone +972 (0)3 613 87 77

www.hasystems.co.il

